

8 7 6 5 4 3 2 1

REVISION HISTORY				
ZONE	REV	DESCRIPTION	DATE	APPROVED BY
	A	INITIAL RELEASE	2019-NOV-18	GCRET

NOTES:

1. APPLICABLE STANDARDS / SPECIFICATIONS:
A. ASME Y14.5-2009 DIMENSIONING AND TOLERANCING
2. ITEM IDENTIFICATION:
MARK OR ATTACH A LABEL TO INDICATE PART NUMBER AND REVISION LEVEL OF COMPONENT.
3. TO BE MADE OUT OF TIN PLATED COPPER BAR.

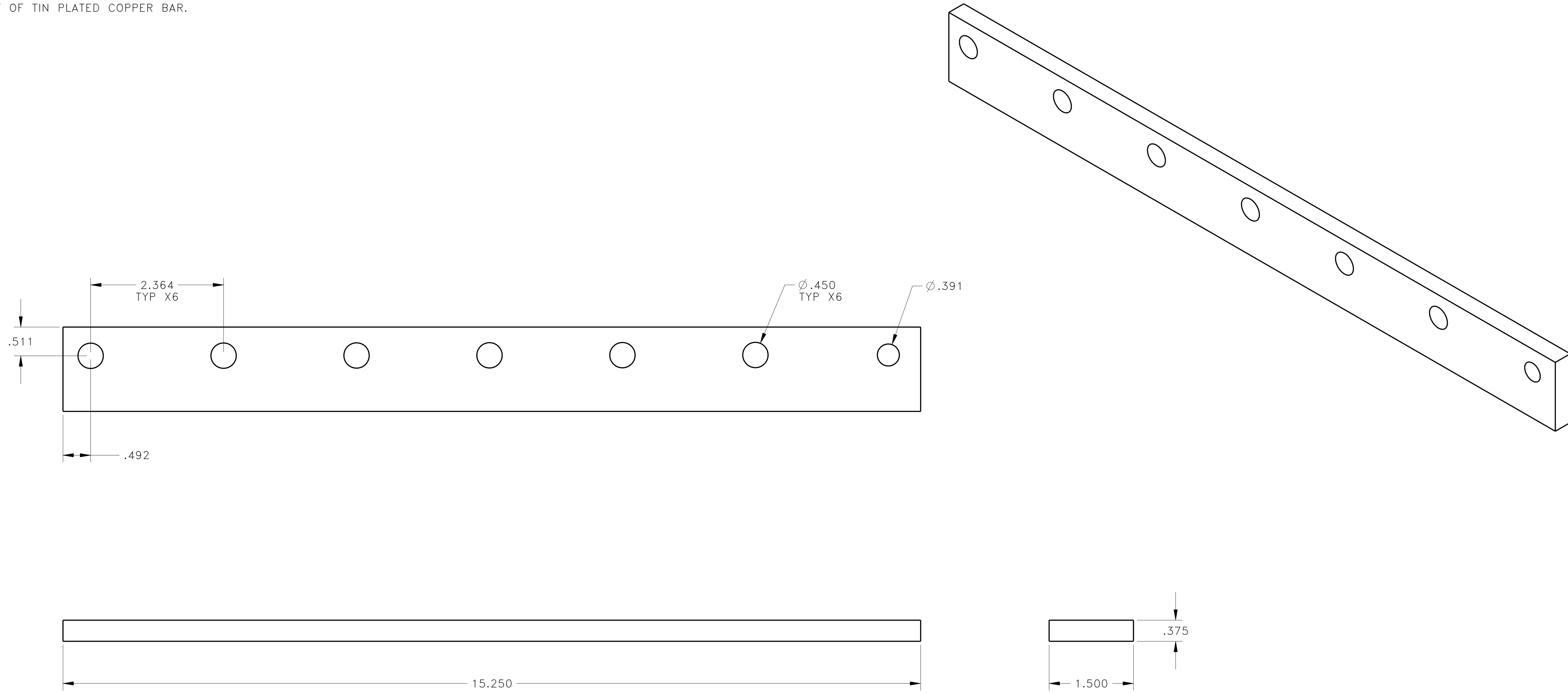

<p>THIS IS A COMPUTER GENERATED DRAWING. DO NOT UPDATE MANUALLY.</p> <p>E-ONE, INC. PROPRIETARY</p> <p>DISTRIBUTION STATEMENT: THIS DOCUMENT CONTAINS E-ONE PROPRIETARY DATA THAT IS PRIVATE AND PRIVILEGED. THIS DOCUMENT SHALL BE MAINTAINED IN CONFIDENCE AND SHALL NOT BE USED FOR MANUFACTURE, DISCLOSED, OR REPRODUCED IN WHOLE OR IN PART WITHOUT THE EXPRESSED WRITTEN CONSENT OF E-ONE, INC.</p>	<p>INTERPRET DRAWING PER ASME Y14.5-2009</p> <p>UNLESS OTHERWISE SPECIFIED DIMENSIONS ARE IN INCHES</p> <p>TOLERANCES</p> <p>ANGLES ± .1°</p> <p>FRACTIONS ± 1/32</p> <p>DECIMALS ± .01, .XX .01, .XXX .001</p> <p>BROKEN EDGES .015 MAX.</p> <p>FILLETS R.015 MAX.</p> <p>PART(S) SHALL BE FREE OF BURRS</p> <p>SURFACE ROUGHNESS 125/</p> <p>DO NOT SCALE THIS DRAWING</p> <p>THIRD ANGLE PROJECTION</p>		<p>E-ONE, INC. 1601 S.W. 37TH AVENUE OCALA, FLORIDA 34474</p>		
			<p>DATE: 2019-DEC-02</p> <p>DRAWN BY: CGLOETZNER</p> <p>ENGINEER:</p> <p>CHECKED BY: GCRET</p> <p>DRAWING APPROVAL: GCRET</p> <p>DESIGN APPROVAL: GCRET</p> <p>SIMILAR TO:</p>	<p>BAR BRASS .375 15.25" 7 HOLE</p>	
<p>SCALE: 1.500</p>		<p>UNIT WT:</p>	<p>DRAWING NUMBER: 1105504</p>	<p>CAGE CODE: 8P082</p>	<p>SHEET: 1 OF 1</p>

8 7 6 5 4 3 2 1