

REVISION HISTORY				
ZONE	REV	DESCRIPTION	DATE	APPROVED BY
A	1	INITIAL RELEASE	2020-FEB-20	GCRET

- NOTES:
- APPLICABLE STANDARDS / SPECIFICATIONS:  
A. ASME Y14.5-2009 DIMENSIONING AND TOLERANCING
  - ITEM IDENTIFICATION:  
MARK OR ATTACH A LABEL TO INDICATE PART NUMBER AND REVISION LEVEL OF COMPONENT.

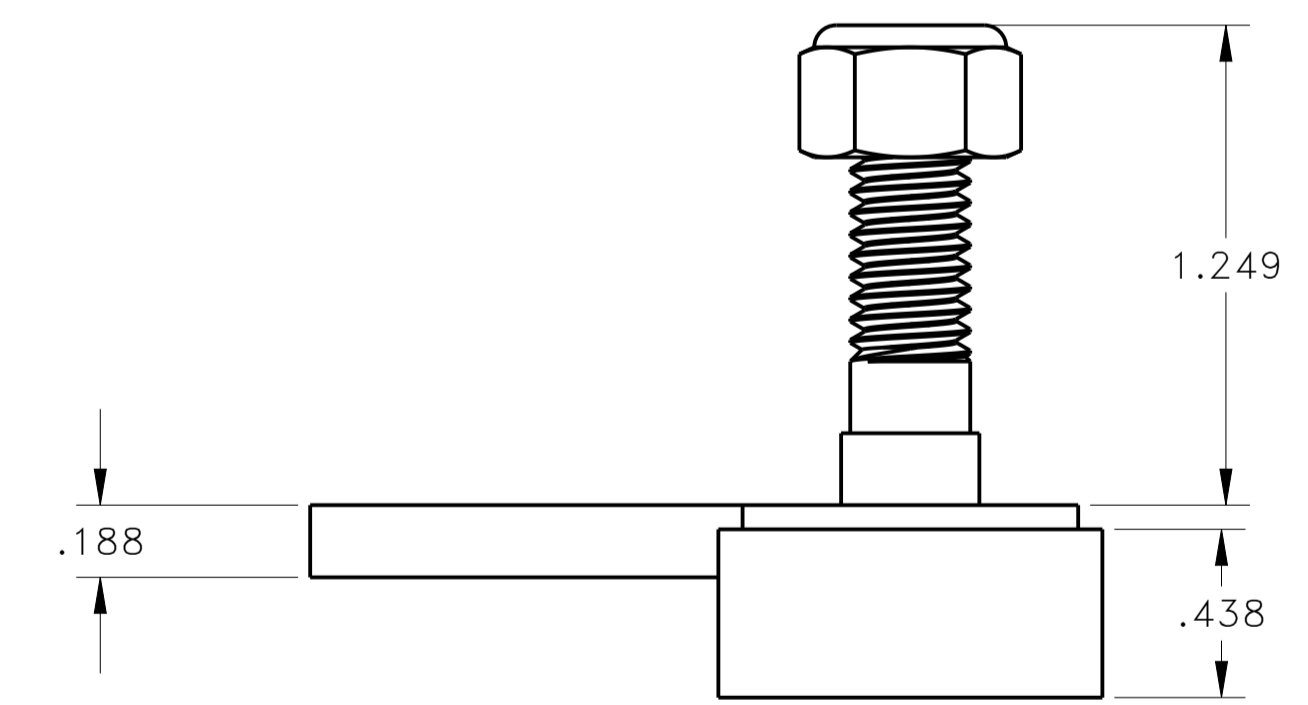
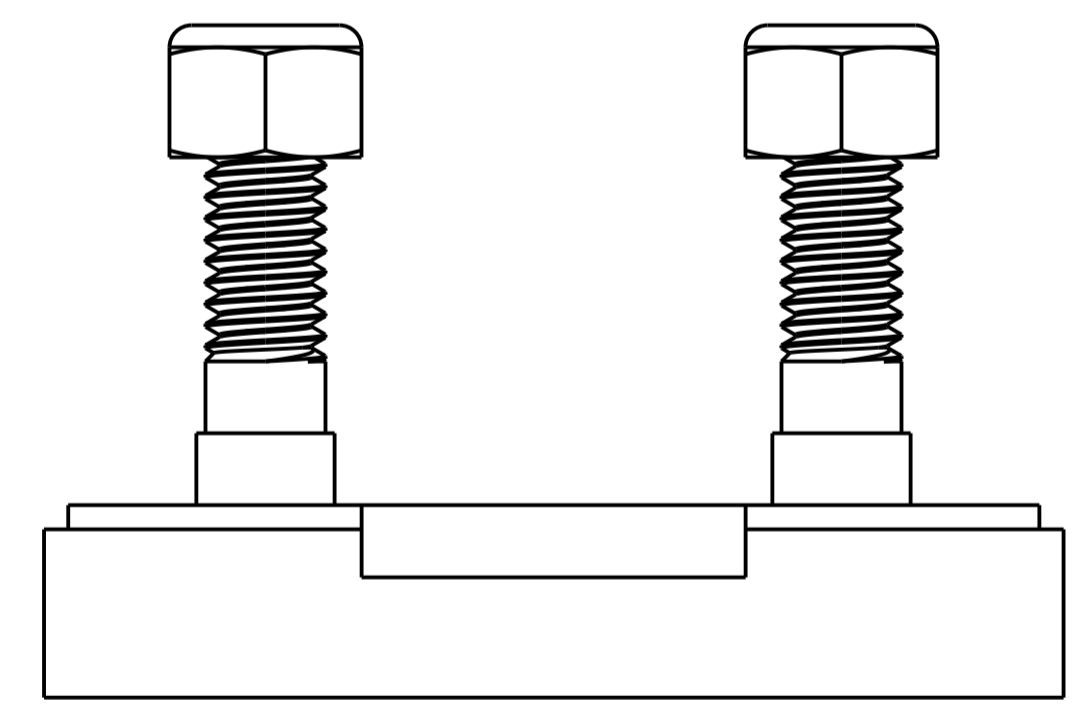
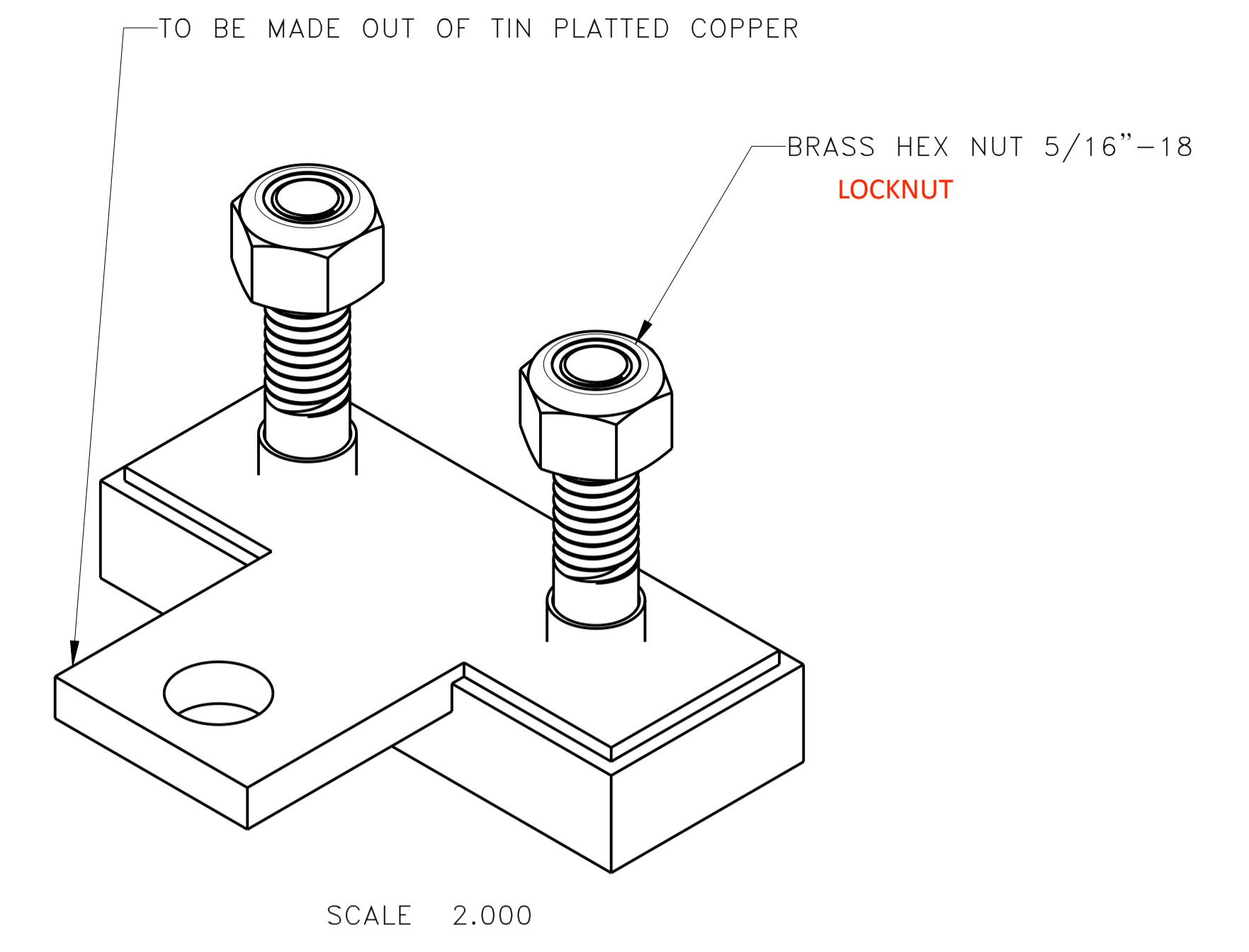
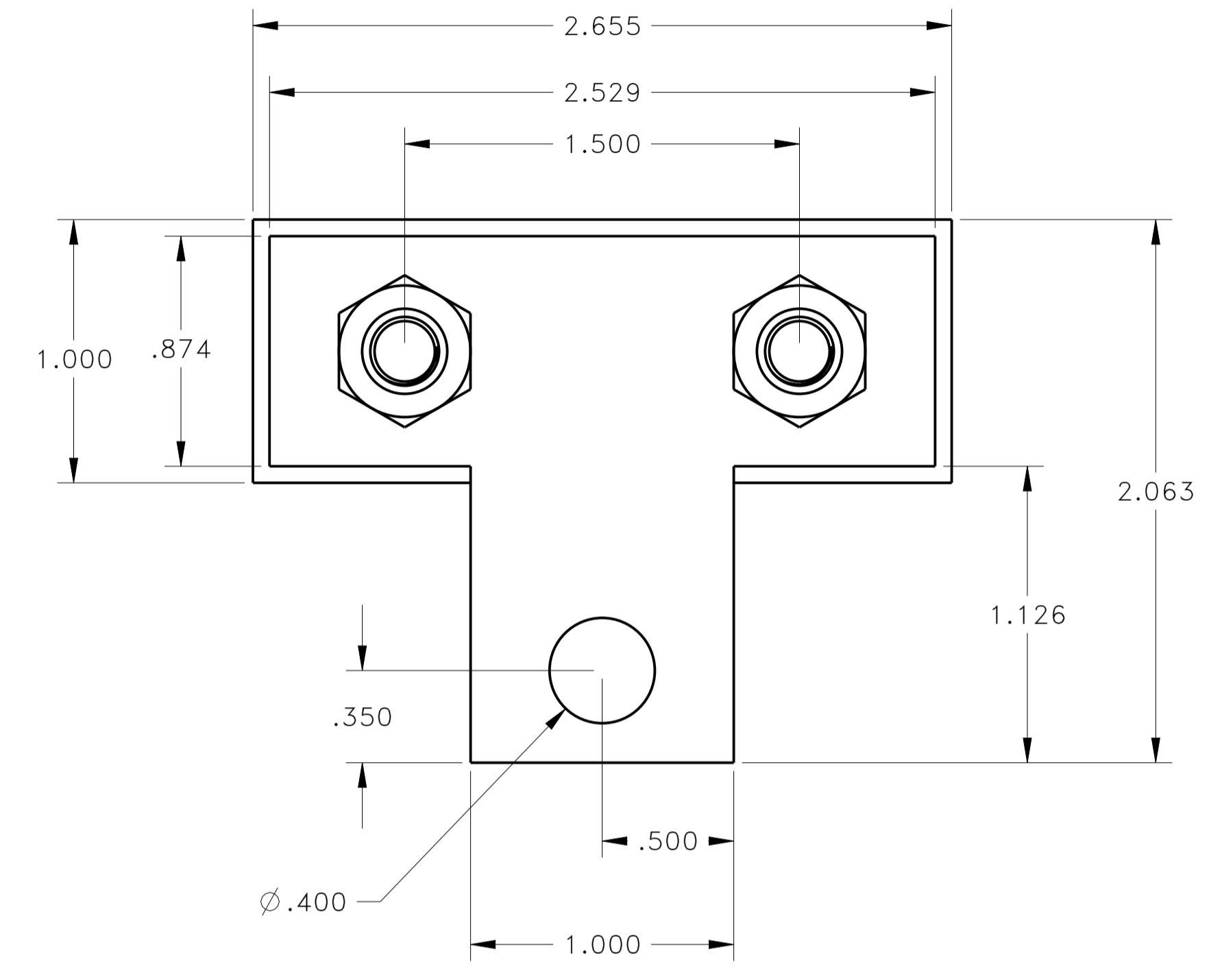

THIS IS A COMPUTER GENERATED DRAWING. DO NOT UPDATE MANUALLY.		INTERPRET DRAWING PER ASME Y14.5-2009				E-ONE, INC. 1601 S.W. 37TH AVENUE OCALA, FLORIDA 34474															
E-ONE, INC. PROPRIETARY		UNLESS OTHERWISE SPECIFIED DIMENSIONS ARE IN INCHES TOLERANCES ANGLES ± .5° DECIMALS ± .01, .XX, .06, .XXX, .031 FRACTIONS ± 1/32 BROKEN EDGES .015 MAX. FILLETS R.015 MAX. PARTS SHALL BE FREE OF BURRS SURFACE ROUGHNESS 125μ DO NOT SCALE THIS DRAWING THIRD ANGLE PROJECTION				<table border="1"> <tr><td>DATE</td><td>2020-FEB-20</td></tr> <tr><td>DRAWN BY</td><td>CGLOETZNER</td></tr> <tr><td>ENGINEER</td><td></td></tr> <tr><td>CHECKED BY</td><td>GCRET</td></tr> <tr><td>DRAWING APPROVAL</td><td>GCRET</td></tr> <tr><td>DESIGN APPROVAL</td><td>GCRET</td></tr> <tr><td>SIMILAR TO</td><td></td></tr> </table>		DATE	2020-FEB-20	DRAWN BY	CGLOETZNER	ENGINEER		CHECKED BY	GCRET	DRAWING APPROVAL	GCRET	DESIGN APPROVAL	GCRET	SIMILAR TO	
DATE	2020-FEB-20																				
DRAWN BY	CGLOETZNER																				
ENGINEER																					
CHECKED BY	GCRET																				
DRAWING APPROVAL	GCRET																				
DESIGN APPROVAL	GCRET																				
SIMILAR TO																					
DISTRIBUTION STATEMENT: THIS DOCUMENT CONTAINS E-ONE PROPRIETARY DATA THAT IS PRIVATE AND PRIVILEGED. THIS DOCUMENT SHALL BE MAINTAINED IN CONFIDENCE AND SHALL NOT BE USED FOR MANUFACTURE, DISCLOSED, OR REPRODUCED IN WHOLE OR IN PART WITHOUT THE EXPRESSED WRITTEN CONSENT OF E-ONE, INC.				<table border="1"> <tr><td>SIZE</td><td>D</td><td>CAGE CODE</td><td>8P082</td><td>DRAWING NUMBER</td><td>1108774</td></tr> <tr><td>SCALE</td><td>2.000</td><td>UNIT WT</td><td></td><td>SHEET</td><td>1 OF 1</td></tr> </table>		SIZE	D	CAGE CODE	8P082	DRAWING NUMBER	1108774	SCALE	2.000	UNIT WT		SHEET	1 OF 1				
SIZE	D	CAGE CODE	8P082	DRAWING NUMBER	1108774																
SCALE	2.000	UNIT WT		SHEET	1 OF 1																