

NOTES:

1. APPLICABLE STANDARDS / SPECIFICATIONS:
  - A. ASME Y14.5-2009 DIMENSIONING AND TOLERANCING
2. ITEM IDENTIFICATION:
 

MARK OR ATTACH A LABEL TO INDICATE PART NUMBER AND REVISION LEVEL OF ASSEMBLY.

REVISION HISTORY				
ZONE	REV	DESCRIPTION	DATE	APPROVED BY
	A	INITIAL RELEASE	2019-DEC-03	GCRET

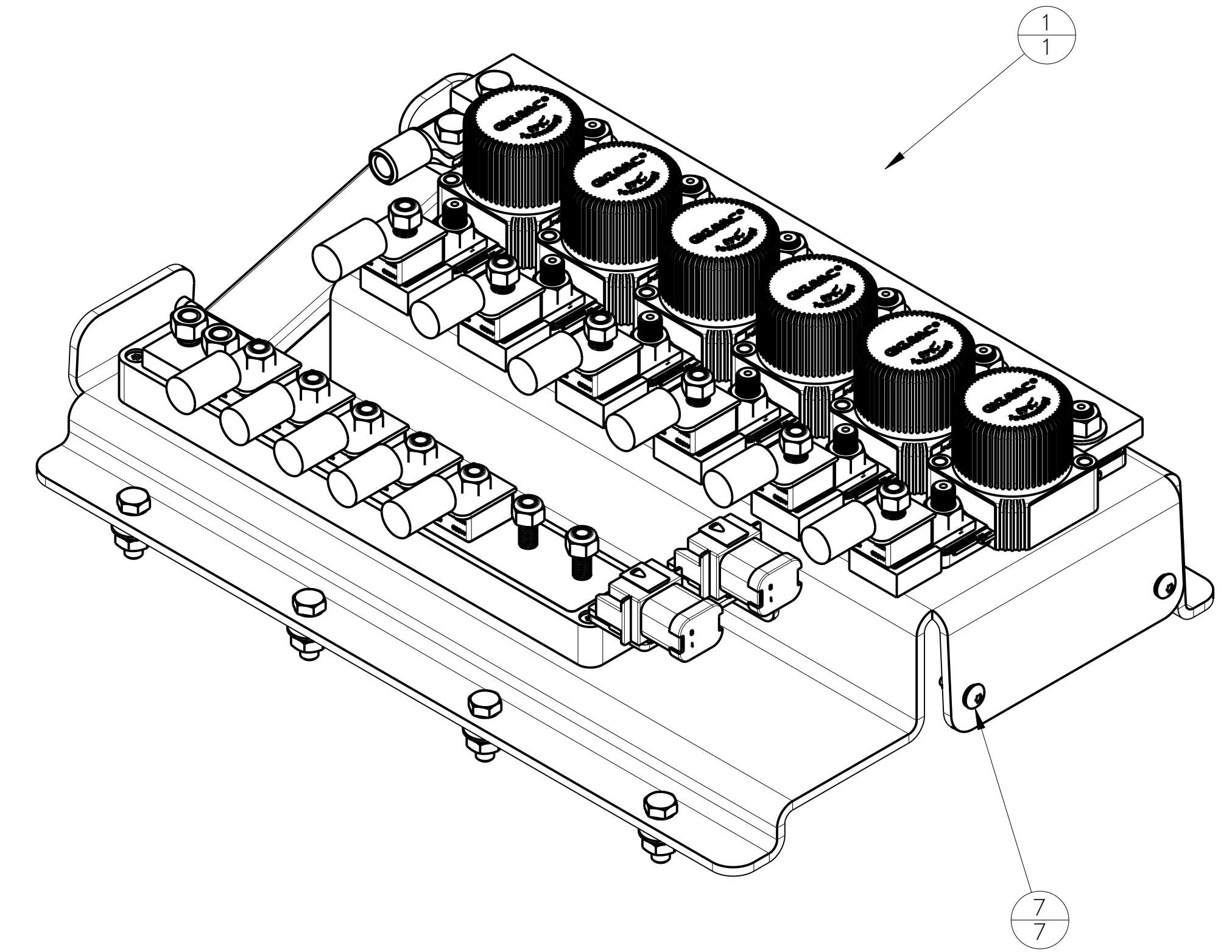
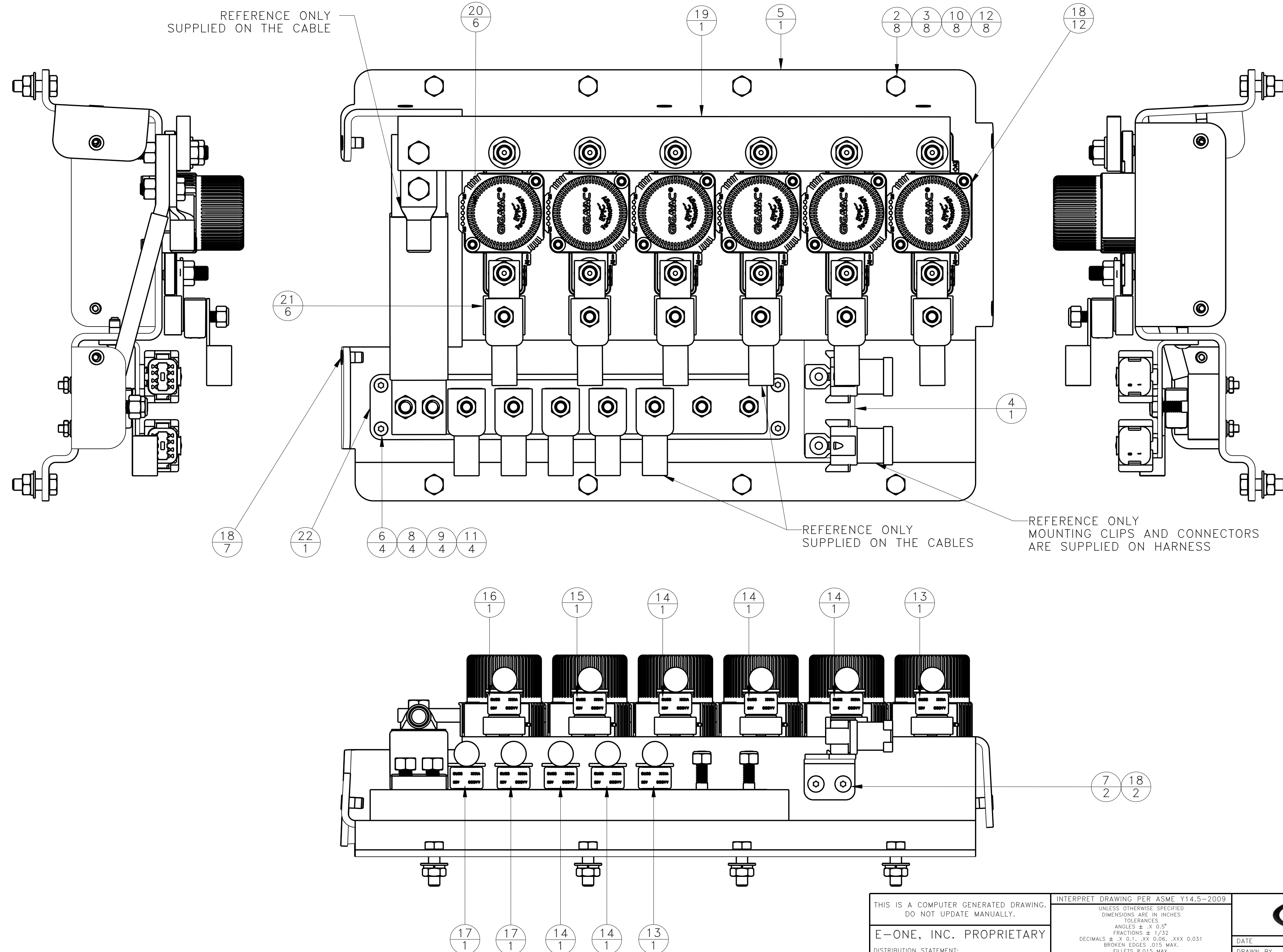

ITEM	QTY	PART NUMBER	NOMENCLATURE OR DESCRIPTION	MATERIAL
22	1	1106194	BUS BAR 7 STUD 621	
21	6	1106071	FUSE STUD 621	
20	6	1105919	SOLENOID 12V 350AMP SPST/NO	
19	1	1105504	BAR BRASS .375 15.25" 7 HOLE	
18	21	703615	INSERTS ALUMINUM 10-24	
17	2	692063	FUSE BUSSMAN MRBF 50 AMP	
16	1	692062	FUSE BUSSMAN MRBF 50 AMP	
15	1	692061	FUSE BUSSMAN MRBF 50 AMP	
14	5	692056	FUSE BUSSMAN MRBF 50 AMP	
13	2	692054	FUSE BUSSMAN MRBF 50 AMP	
12	8	200046	WASHER .3125 FLAT SS	
11	4	200021	NUT 10-24 HEX SS	
10	8	200001	BOLT 5/16-18 X 1.000 SS HEX HD	
9	4	200044	WASHER #10 SS FLAT	SS
8	4	200036	WASHER #10 SS LOCK	SS
7	9	533828	SCREW 10-24X.75 TRUSS TORX MS SS	COST
6	4	533824	10-24X1-1/4 PAN TORX MS SS	COST
5	1	1105443	BRKT P8AT PDC	371002
4	1	1106157	BRKT DEU CLIPS	371001
3	8	200023	.313 HEX NUT	200023
2	8	200038	WASHER .313 SS LOCK	
1	1	1105448	CVR PLAS PDC P8AT	

THIS IS A COMPUTER GENERATED DRAWING. DO NOT UPDATE MANUALLY.

**E-ONE, INC. PROPRIETARY**

DISTRIBUTION STATEMENT:  
THIS DOCUMENT CONTAINS E-ONE PROPRIETARY DATA THAT IS PRIVATE AND PRIVILEGED. THIS DOCUMENT SHALL BE MAINTAINED IN CONFIDENCE AND SHALL NOT BE USED FOR MANUFACTURE, DISCLOSED, OR REPRODUCED IN WHOLE OR IN PART WITHOUT THE EXPRESSED WRITTEN CONSENT OF E-ONE, INC.

INTERPRET DRAWING PER ASME Y14.5-2009

UNLESS OTHERWISE SPECIFIED DIMENSIONS ARE IN INCHES

TOLERANCES

ANGLES ± .5°

FRACTIONS ± 1/32

DECIMALS ± .X 0.1, .XX 0.06, .XXX 0.031

BROKEN EDGES .015 MAX.

FILLET R.015 MAX.

PARTS SHALL BE FREE OF BURRS

SURFACE ROUGHNESS 125/

DO NOT SCALE THIS DRAWING

THIRD ANGLE PROJECTION

<b>E-ONE</b>	
DATE	2019-DEC-03
DRAWN BY	CGLOETZNER
ENGINEER	
CHECKED BY	RMILLET
DRAWING APPROVAL	GCRET
DESIGN APPROVAL	GCRET
SIMILAR TO	

E-ONE, INC. 1601 S.W. 37TH AVENUE OCALA, FLORIDA 34474		
<b>ASSY P8AT PDC</b>		
SIZE	CAGE CODE	DRAWING NUMBER
D	8P082	1105444
SCALE	UNIT WT	SHEET
.600		1 OF 2

8

7

6

5

4

3

2

1

D

D

C

C

B

B

A

A



SIZE	CAGE CODE	DRAWING NUMBER	REV
D	8P082	1105444	A
SCALE	.250	UNIT WT	SHEET 2 OF 2