

SP01	
WIRE	TARGET
GND	J1:1
GND	J2:4
GND	J3:1

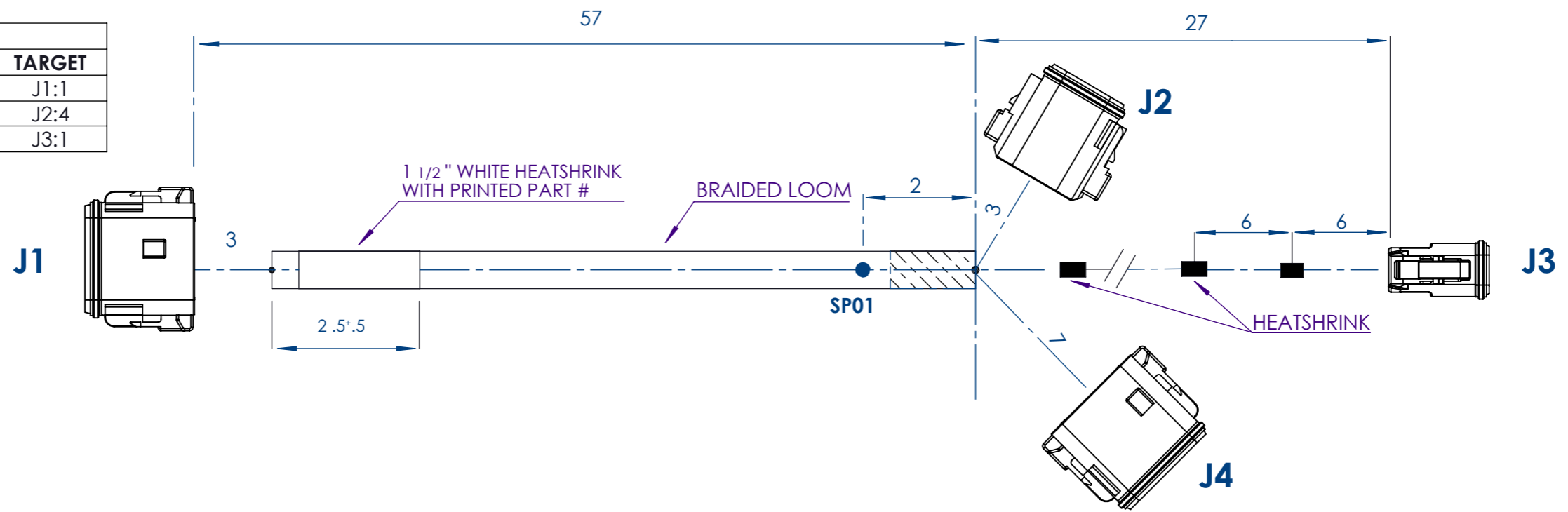

J1		J2		SPICE	J3		J4		WIRE					
TO TAG I/O CONTROLLER		TO BOTTOM I/O CONTROLLER			TO BREATHING AIR ALARM		TO BREATHING AIR SENSOR							
DEUTSCH DT06-12SA-P012		DEUTSCH DT06-08SB-P012		SP01	DEUTSCH DT06-2S		DEUTSCH DT06-12SC-P012		ID	TWISTED PAIRS*	COLOR	AWG	LENGTH (INCH)	
PIN #	CODE	PIN #	CODE		PIN #	CODE	PIN #	CODE						
11	J	1	J						CAN(0) HI	TWISTED PAIRS	YELLOW	18	65	
2	J	2	J						CAN(0) LO		GREEN	18	65	
12	J	3	J						POWER		RED	18	62	
1	J	4	J	SP01					GND		BLACK	18	62	
				SP01	1	J			GND	TWISTED PAIRS	BROWN	18	32	
8	J				2	J			AUX 0		ORANGE	18	87 1/4	
6	J	6	J						E-STOP OUT		BLUE	18	62	
3	J	7	J						CAN(1) LO	TWISTED PAIRS	GREEN	18	65	
10	J	8	J						CAN(1) HI		YELLOW	18	65	
7	J	5	J						E-STOP IN		BLUE	18	62	
5	J							11	J	AUX 1	WHITE	18	66	
W12S-P012		W8S-P012			W2S		W12S-P012		<b>WEDGE LOCK PLUG</b>					
0413-217-1605							0413-217-1605							

PIN CODE	PART #	TOTAL
J	0462-201-16141	21

\*IF APPLICABLE TWISTING SHOULD NOT BE LESS THAN ONE TWIST PER INCH UNLESS OTHERWISE SPECIFIED  
ALL SPLICES SHOULD BE COVERED WITH APPROPRIATE HEATSHRINK IF APPLICABLE

				SCALE: NONE	DO NOT SCALE DRAWING	REVISION 1.0
TITLE: <b>TURN TABLE HARNESS-H6</b>				621 Technologies inc.		
DWG NO. ALCTC-001-H6		A3		DIMENSIONS ARE IN INCHES UNLESS UNTIL SPECIFIED		
SHEET 2 OF 2						

All data and drawings are sent without acknowledgement of a legal obligation, without guarantee of completeness and without promise of warranty. The data provided were ascertained using extreme care. However, possible sources of error cannot be excluded completely. We therefore do not accept any responsibility for damage and costs that may result from the use of these data. Binding data are to be taken exclusively from our drawings that are subject to confirmation. These contents are confidential and property of 621 inc., so it must not be copied or submitted to third parties for use or examination.

Dimensions are approximate. For representation only. Tolerances except where otherwise stated .X = +/- 0.25

NAME	SIGNATURE	DATE
DRAWN Charles Jacob	CJ	2/13/19
CHK'D Alexandr belii	AB	2/14/19
APPV'D Dan Lafon	DL	2/14/19
MFG		
Q.A		