

NOTES:

1. APPLICABLE STANDARDS / SPECIFICATIONS:
A. ASME Y14.5-2009 DIMENSIONING AND TOLERANCING
2. ITEM IDENTIFICATION:
MARK OR ATTACH A LABEL TO INDICATE PART NUMBER AND REVISION LEVEL OF COMPONENT.
3. TO BE MADE OUT OF TIN PLATED COPPER WITH RED POWDER COAT COVERING ALL SURFACES EXCLUDING WHERE NOTED.

| REVISION HISTORY | | | | |
|------------------|-----|-----------------|-------------|-------------|
| ZONE | REV | DESCRIPTION | DATE | APPROVED BY |
| | A | INITIAL RELEASE | 2021-JUN-01 | GCRET |

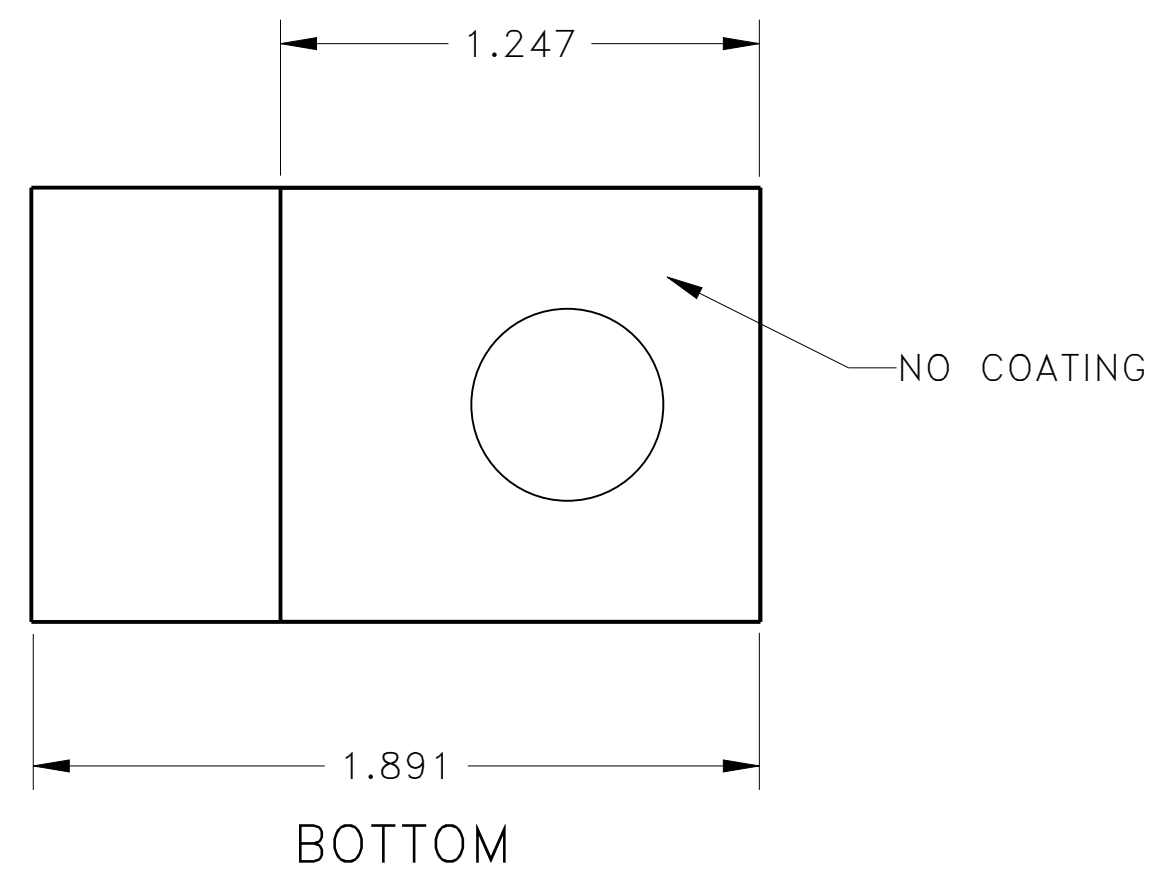
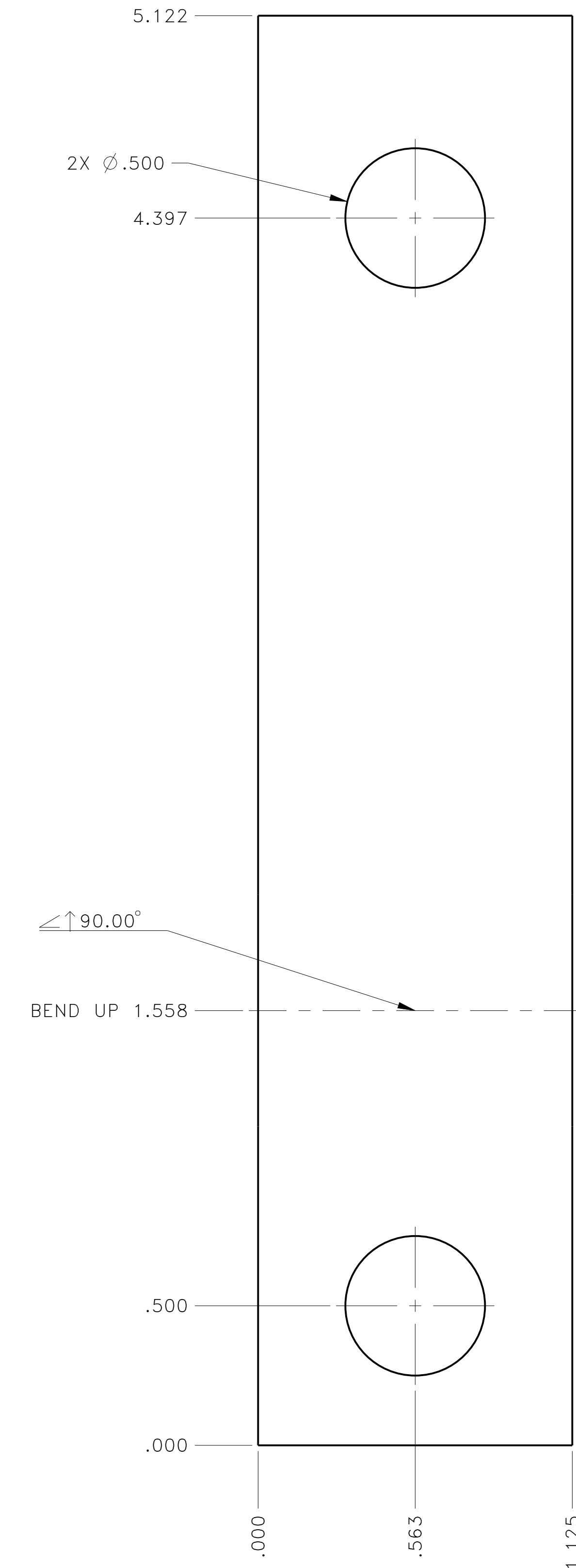
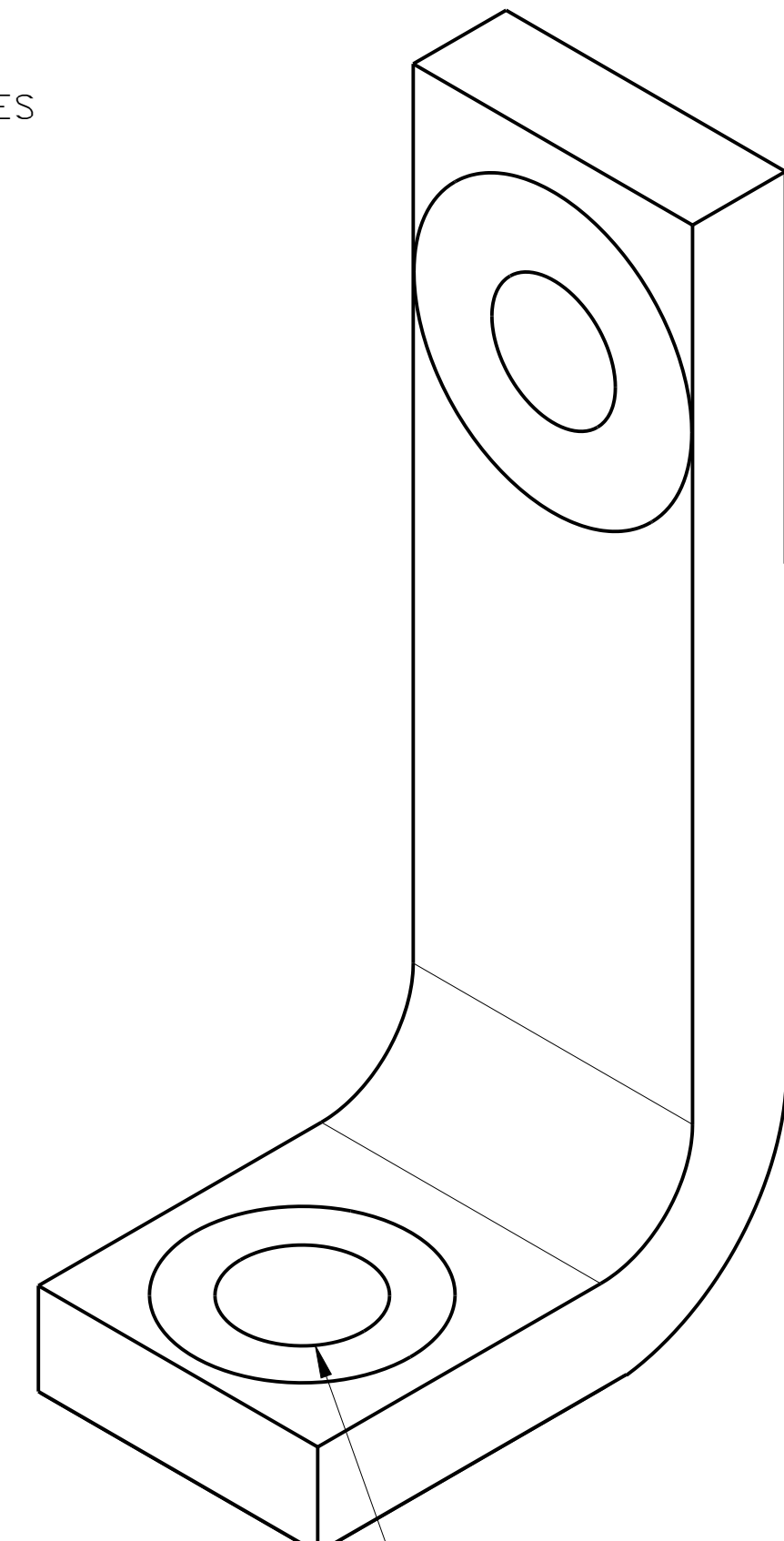
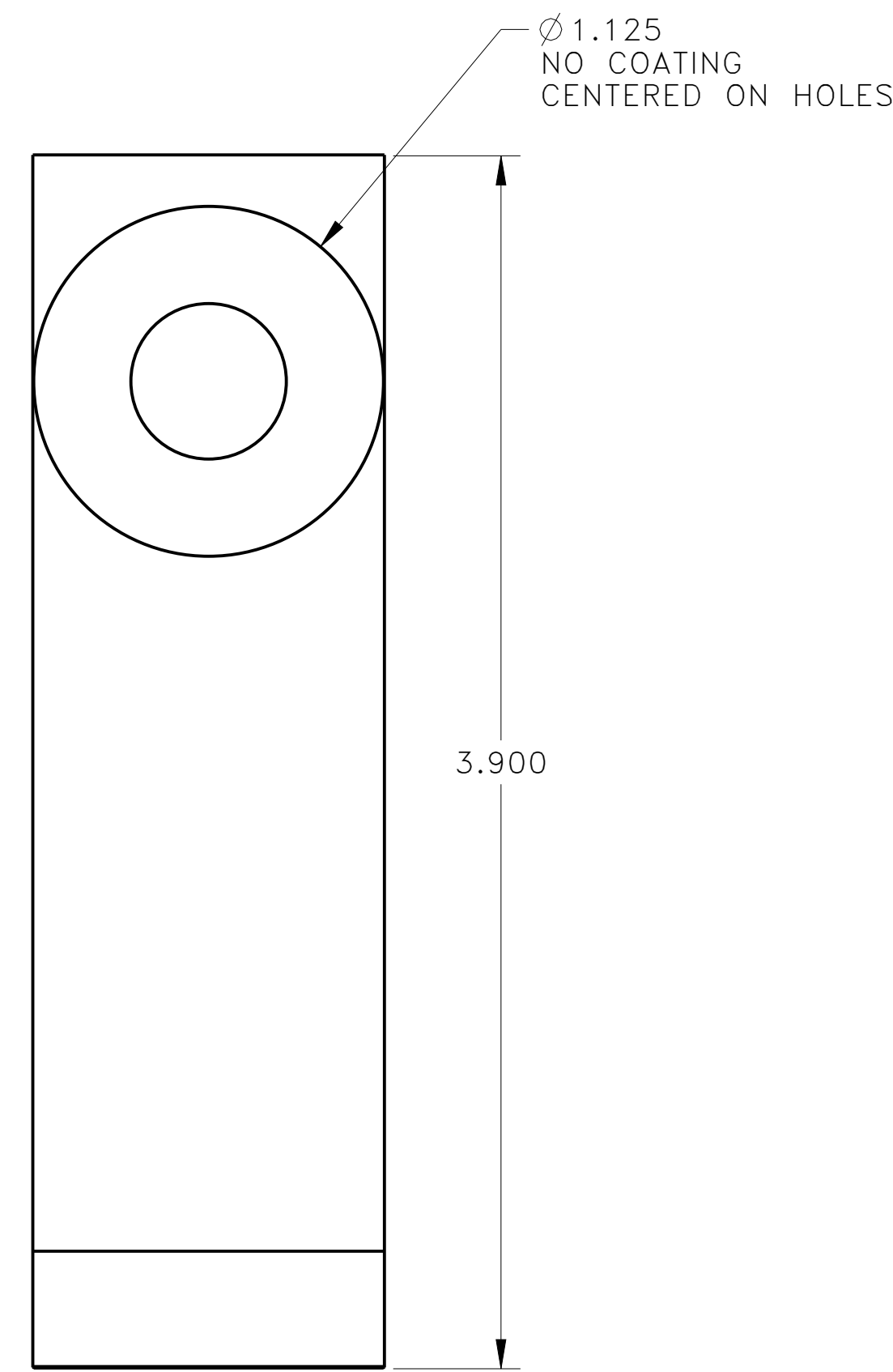
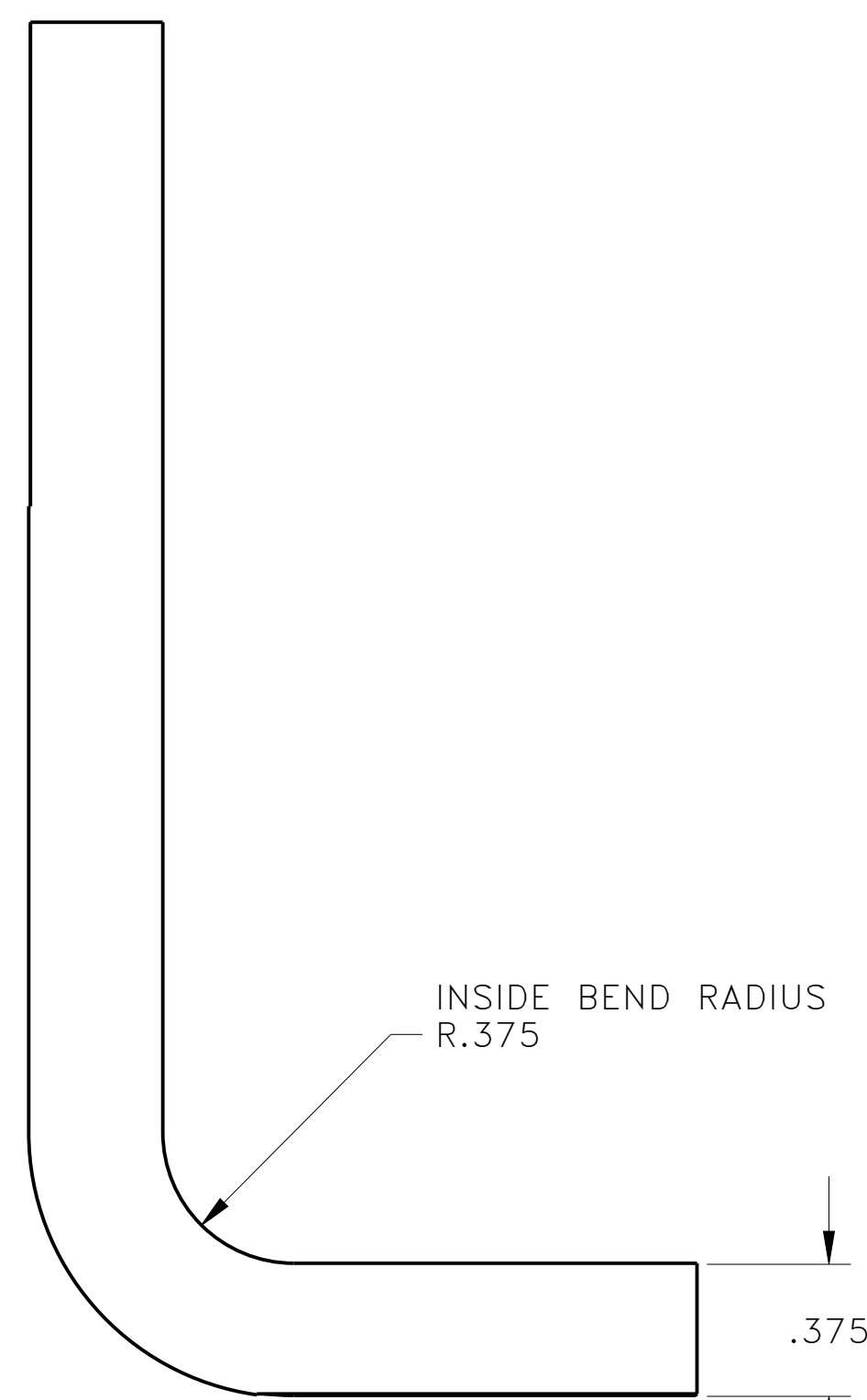
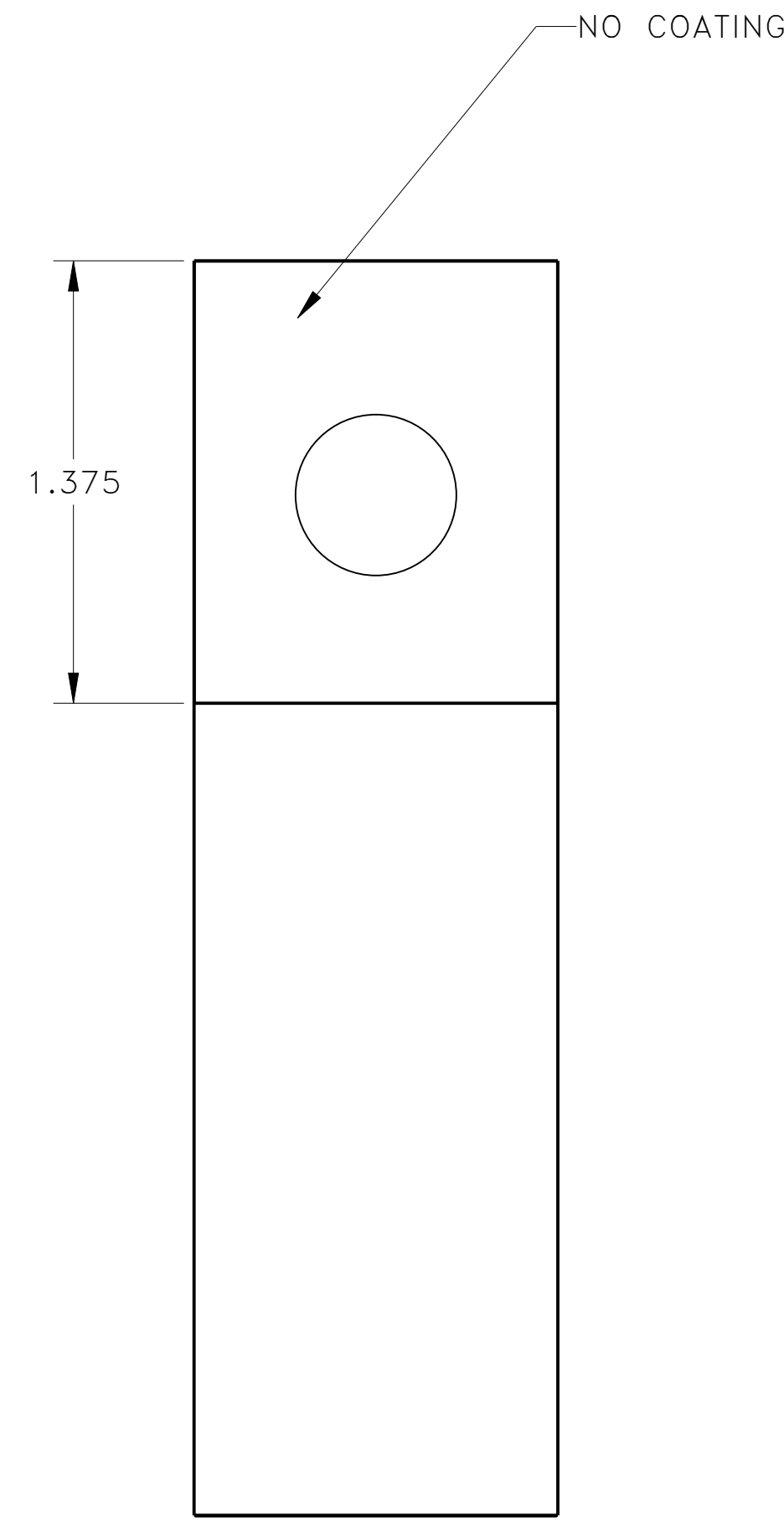
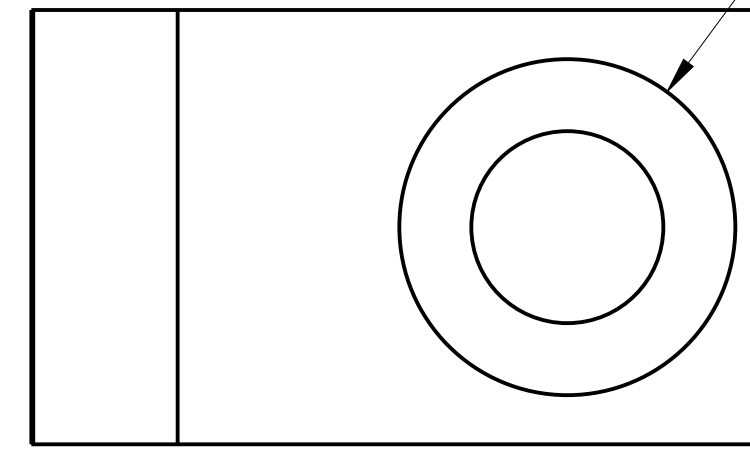
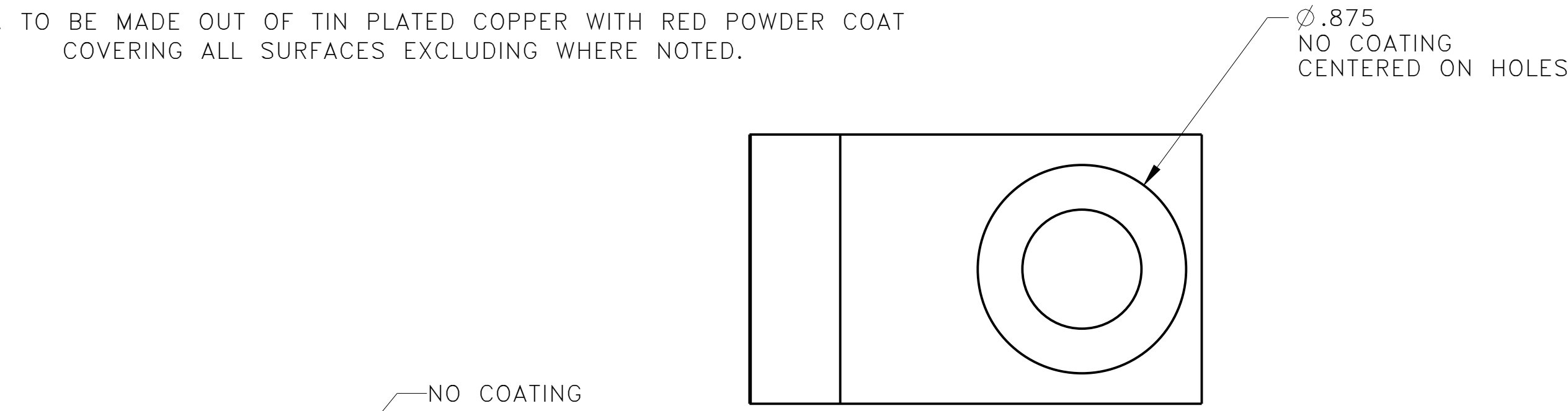

TO BE SUPPLIED
1x Brass Hex Head 3/8"-16, 1 1/2"
1x Brass Locknut 3/8" - 16
2 x Brass washer 3/8"

THIS IS A COMPUTER GENERATED DRAWING.
DO NOT UPDATE MANUALLY.

E-ONE, INC. PROPRIETARY

DISTRIBUTION STATEMENT:
THIS DOCUMENT CONTAINS E-ONE PROPRIETARY
DATA THAT IS PRIVATE AND PRIVILEGED. THIS
DOCUMENT SHALL BE MAINTAINED IN CONFIDENCE
AND SHALL NOT BE USED FOR MANUFACTURE,
DISCLOSED, OR REPRODUCED IN WHOLE OR IN
PART WITHOUT THE EXPRESSED WRITTEN CONSENT
OF E-ONE, INC.

INTERPRET DRAWING PER ASME Y14.5-2009

UNLESS OTHERWISE SPECIFIED
DIMENSIONS ARE IN INCHES

TOLERANCES

ANGLES ± .1°

FRACTIONS ± 1/32

DECIMALS ± .001, .XX .06, .XXX .031

BROKEN EDGES .015 MAX.

FILLETS R.015 MAX.

PART(S) SHALL BE FREE OF BURRS

SURFACE ROUGHNESS 125/

DO NOT SCALE THIS DRAWING

THIRD ANGLE PROJECTION

| | |
|------------------|-------------|
| E-ONE | |
| DATE | 2021-MAY-25 |
| DRAWN BY | CGLOETZNER |
| ENGINEER | |
| CHECKED BY | TCUPPY |
| DRAWING APPROVAL | GCRET |
| DESIGN APPROVAL | GCRET |
| SIMILAR TO | |

| | | | |
|--|-----------|----------------|--|
| E-ONE, INC. 1601 S.W. 37TH AVENUE OCALA, FLORIDA 34474 | | | |
| BAR MPD SOLENOID BRIDGE 2021 | | | |
| SIZE | CAGE CODE | DRAWING NUMBER | |
| D | 8P082 | 1123030 | |
| SCALE | UNIT WT | SHEET | |
| 2.000 | | 1 OF 1 | |